

# DONZI

## 8 FOOT DINK



The eight foot DONZI dink can be carried in a station wagon or car-topped. It also fills the need for yachtsmen that do not have sufficient room for the ten footer...

L.O.A.	8 feet	
Width	44 in.	
Transom	17 3/4 in.	<b>\$295</b>
H.P. rec	To 5 H.P.	F.O.B. FACTORY

Complete with:

- Full Inner-liner
- Flotation
- Full non-skid molded into bottom
- Self-bailing dry well
- Oar Locks
- Aluminum/vinyl rub rail
- Drain Plug
- SS bow eye
- 3 chrome lifting handles

DONZI MARINE, INC.  
2940 N.E. 188th Street  
North Miami Beach, Florida 33160



Presents  
**THE DINK**

....The all fiberglass eight and ten foot DONZI dinks, designed by Al Pflueger, have been developed to fill the need for a truly versatile dink....

DONZI MARINE, INC.  
2940 N.E. 188th Street  
North Miami Beach, Florida 33160

305-945-7510  
Cable: DAMDONZI

## 10 FOOT DINK

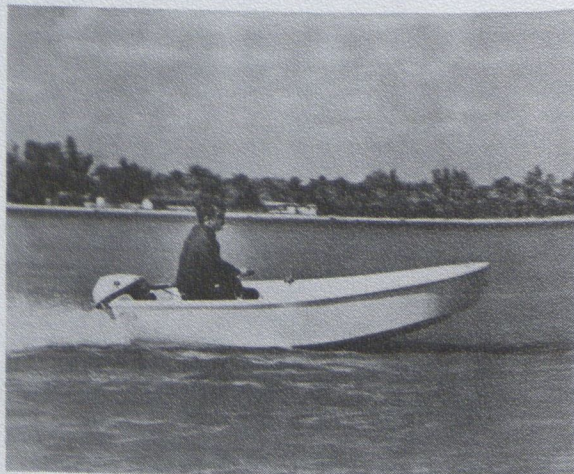

The ten foot DONZI dink can be car-topped, or for the yachtsman who wishes to tow it through rough seas its keel assures smooth tracking.

L.O.A. 10 feet  
 Width 57 1/2 in.  
 Transom 15 1/2 in.  
 H.P. rec. To 10 H.P.

**\$395**  
 F.O.B. FACTORY

### Complete with:

- Full Inner-liner
- Flotation
- Full non-skid molded into bottom
- Oar Locks
- Aluminum/Vinyl rub rail
- Drain plug
- SS bow eye
- 3 lifting rings
- Self-bailing dry well

## DONZI Peek-a-Boo Dink

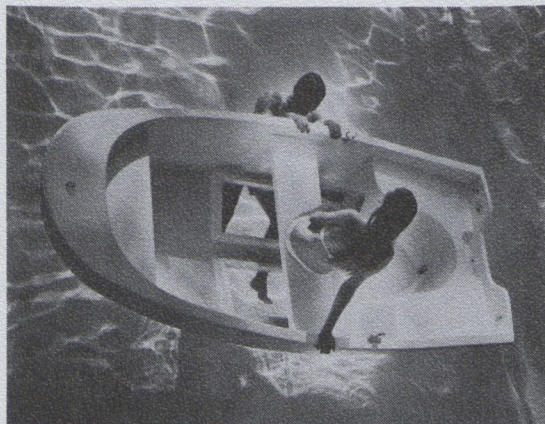

The DONZI "Peek-a-Boo" dink is ideal for the skin-diving enthusiast. It provides excellent underwater viewing and its stability makes entering the boat from the water easy.

L.O.A. 10 feet  
 Width 57 1/2 in.  
 Transom 15 1/2 in.  
 H.P. rec. To 10 H.P.

**\$445**  
 F.O.B. FACTORY

### Complete with:

- Full Inner-liner
- Flotation
- Full non-skid molded into bottom
- Two large glass viewing panels
- Oar Locks
- Aluminum/vinyl rub rail
- Drain plug
- SS bow eye and 3 lifting rings
- Self-bailing dry well

## DINK SAIL-BOAT



The DONZI sailing "Peek-a-Boo" dink is exciting to the Captain and crew as the secrets of the ocean come to life and unfold new adventures with every tack.

L.O.A. 10 feet  
 Width 57 1/2 in.  
 Transom 15 1/2 in.

**\$795**  
 F.O.B. FACTORY

### Complete with:

- Anodized aluminum center board
- Anodized aluminum mast & boom
- Rudder
- Tiller Arm
- SS Hardware
- Nylon blocks
- Sliding gunther rig
- 61 feet of sail on 10 footer
- Dacron sail and thread

**DONZI MARINE**  
 DESIGNERS AND BUILDERS OF  
 THE WORLD'S FINEST HIGH PERFORMANCE POWER BOATS  
 presents

THE  
**DONZI 16**

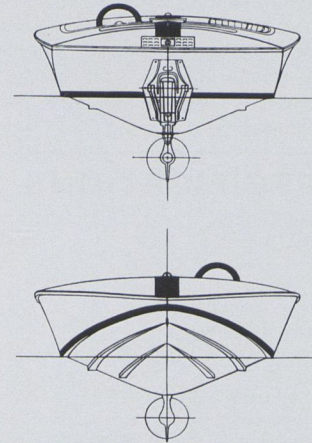
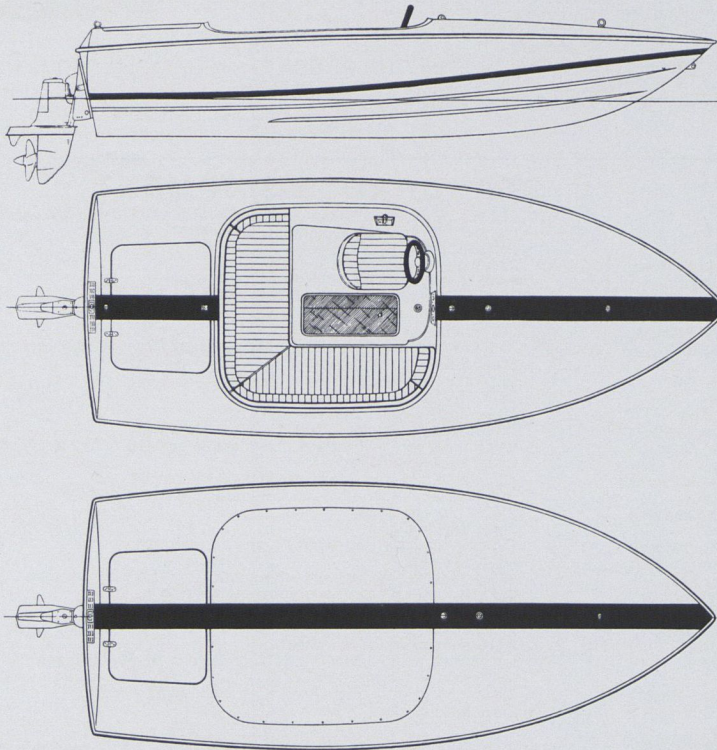

- SOFTEST RIDING, DRIEST HIGH-SPEED SPORTS BOAT EVER BUILT
- INCOMPARABLE HIGH-PERFORMANCE, CUSTOM-FINISHED SPORT-SKI BOAT
- FINEST ALL-AROUND CUSTOM PERSONAL BOAT BUILT TODAY
- HI-IMPACT FIBREGLASS CONSTRUCTION
- TEST MODEL HOLDER OF 8 WORLD MARATHON RECORDS

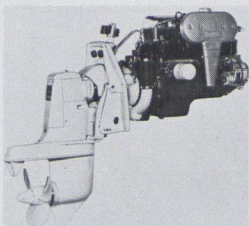

1.

1. Volvo Aquamatic 200 outdrive features electric lift, underwater exhaust, integral steering and shift controls, new kick-up locking device, 65 degree tilt. New Volvo 110 Engine features full corrosion-proofing, increased water pump capacity, moisture proof ignition, maximum fuel economy.
2. Radical bottom design prevents excessive bow lift during acceleration, yet reduces drag at speed. Softest, driest ride ever in a sports boat. (Patent 3,162,167).
3. Superior guard rail protection against hull damage is provided

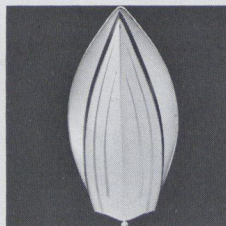

2.



3.

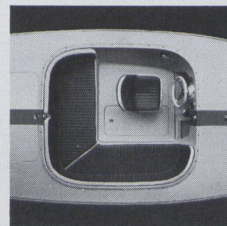

4.

- by double strength fibreglass design during construction. Outer rub strip is heavy duty solid bright aluminum.
4. Interior arrangement provides maximum comfort and safety for five adults. L-shaped lounge allows comfortable position for water ski observer facing aft. An original layout by our designers.
5. International running lights insure safe night operation and avoid use of ungainly telescoping stern light.
6. Bucket seat adjusts fore and aft, rotates 360 degrees to fit individual seating requirements with maximum high speed comfort and safety.

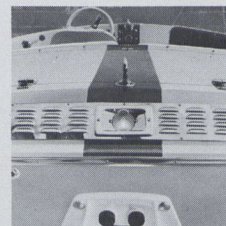

5.



6.

The racy, rugged Donzi 16 is the high-spirited product of the most advanced engineering to be found in the custom boat field today. In it are incorporated radical hull, strake and chine improvements born of blue-water competition racing; structural features developed by the world's foremost small craft designers; a gracefully sweeping silhouette — fore, aft or broadside — which is a refinement of the pure lines of European boats which heretofore have been unmatched for water-borne beauty. The Donzi 16 has been refined, tested and proved for 3 years. Hull and strake designs have been proven in the Wyn-Mill II, test model holder of 8 world marathon records. The Donzi 16 has incredible maneuverability, with com-

plete visibility at all speeds, full stability, and less slip in turns than any other boat in its class. Multiple spray rails provide a dry, comfortable ride at any speed. Multi-laminate fibreglass hull of semi-cored construction has high impact strength, no exterior seams, is lightweight yet has extreme rigidity. Built-in safety factors include heavy deep-foam seat cushions, snag-free cockpit, dished H.D. race wheel, electric automatic bilge pump, bilge blower, and fire extinguisher. Every Donzi 16 is thoroughly tested before delivery. When you step aboard she is fully equipped and ready to go — to give you a world of boating pleasure...and no "bugs" to eliminate. Mirror-smooth, Wonder White gel coat is easily maintained, tough, has permanent high-gloss finish.



## BUILDER-DESIGNER'S DREAM COME TRUE

Designed by a team headed by Don Aronow, internationally known marine consultant, designer, ocean racer and builder, (the same team that designed, raced, and owned the Formula 233, 275 and Formula Jr.). The Donzi 16 has all the sleek good looks of a show boat, the speed and flexibility of the finest sports boat and the stamina of a marathon competitor. It incorporates all the fine features that Aronow and the team have dreamed for years of putting in a small production boat. The result is European styling combined with fiery performance and spectacular stability. The Donzi 16 is an engineer's boat, a man's boat... a brute for strength, with the instantaneous response of a fine sports car.

Try driving a Donzi 16... you'll never again be satisfied with an ordinary boat.

## SPECTACULAR RACE RECORD OF WYN-MILL II, DONZI 16 TEST BOAT

YEAR, EVENT & LOCATION	AWARDS	YEAR, EVENT & LOCATION	AWARDS
1963 Paris 6-Hour Race Paris, France	Index of Performance, Class IR Tourist, 1st Place, Class IR Sport, 1st Place President Charles DeGaulle Trophy	1965 Foote's Bay Regatta	1st Overall
1962 9-Hour Endurance Miami, Florida	4 UIM Approved World Records 1st Place Class B Racing Runabout	1965 Baysville Regatta	1st In Class
1963 9-Hour Endurance Miami, Florida	4 UIM Approved World Records 1st European Tourist Racing Runabout	1965 Canadian National Exhibition Race	1st Class 1
1962 Miami-Bimini-Miami Atlantic Ocean	1st Place, Class 1 Inboard	1965 9-Hour Endurance 1965 St. Pete 50 Mile Ocean Race 1965 Gulfstream 100 Miler	1st Class 1 1st Class 1



**FOR THE ROUGH WATER EVALUATION THE WYN-MILL II ALSO COMPETED IN:**

**GOLD COAST MARATHON  
MIAMI-NASSAU RACE  
AROUND MIAMI BEACH RACE  
AROUND NASSAU RACE**

## SPECIFICATIONS

<b>LENGTH OVERALL</b>	16'7½"
Including Outdrive	18'4½"
<b>BEAM</b>	7'0"
<b>DRAFT TO KEEL</b>	1'0"
To Bottom of Outdrive	2'3"
<b>FREEBOARD AT BOW</b>	1'8"
Amidship	1'9"
At Transom	1'4"
<b>HEIGHT, TOP OF WHEEL TO KEEL</b>	3'6"
Top of Deck to Keel	3'1½"
<b>GROSS WEIGHT</b>	1500 lbs. approx.
<b>FUEL CAPACITY</b>	25 Gal.
<b>SPEED (STANDARD 110 VOLVO)</b>	40.6 mph
165 Interceptor	49.1 mph
<b>CRUISING RANGE AT 4000 RPM</b>	225 mi. approx.
Cruising Time at 4000 RPM	7 hrs. approx.
<b>POWER</b>	110 Volvo on 200 Aquamatic Outdrive
<b>STEERING</b>	Custom Mechanical
<b>CONTROLS</b>	Custom Throttle and Shift
<b>HARDWARE</b>	Chrome on Brass or Stainless Steel

## STANDARD EQUIPMENT

<b>Power</b>	110 HP Volvo Penta Inboard/Outboard with Volvo-Penta 200 Aquamatic outdrive, electric lift, underwater exhaust, Alternator
<b>Steering</b>	Positive, mechanical, with custom adaptor
<b>Electric System</b>	12 V, color coded
<b>Instruments</b>	Volvo instruments on molded fiberglass panel
<b>Controls</b>	Custom Walnut knob on single lever shift throttle combination
<b>Battery</b>	12 V, 65 amp-hour w/shut off switch
<b>Battery Bracket</b>	Coated steel, racing strength
<b>Fuel System</b>	25 Gallon, custom tank, direct reading gauge filter, shut off, chrome on brass filler and vent
<b>Engine Filters</b>	Oil, water, air and fuel filters all std.
<b>Blower</b>	12 V, Electric
<b>Bilge Pump</b>	12 V, Automatic and manual submersible
<b>Running Lights</b>	International, stainless steel, recessed stern light
<b>Engine Hatch</b>	Reinforced, cored fiberglass, flush lock, removable, extra large, custom hinges
<b>Storage</b>	Under cockpit, with hatch
<b>Engine Ventilation</b>	Adjustable louvered intake, custom exhaust outlet
<b>Rub Rails</b>	High impact molded fiberglass, integral, custom flush trim
<b>Fire Extinguisher</b>	2½ lb. dry chemical
<b>Tools</b>	Volvo Engine Kit
<b>Operation Manual</b>	Engine Manual, wiring diagram, care and maintenance
<b>Ski Storage Rack</b>	Fiberglass, Built In
<b>Bucket Seat</b>	360 degree radius, fore and aft adjustment, foam filled, custom
<b>Upholstery</b>	Custom, water proof, foam, zippered, removable
<b>Tonneau Cover</b>	Nylon zippered, with stripe and removable folding bow
<b>Color Choice</b>	3 choices of upholstery and striping, all hulls Wonder White
<b>Propeller</b>	3 blade aluminum speed wheel
<b>Hardware</b>	Lifting ring with custom brackets, drain plug, vents, towing eye, see-thru fuel gauge cover
<b>Steering Wheel</b>	Custom heavy duty, fast curve, deep dish racing wheel
<b>Oil &amp; Lubricant</b>	Volvo Special lubes

Prices, Specifications and Standard Equipment subject to change without notice.

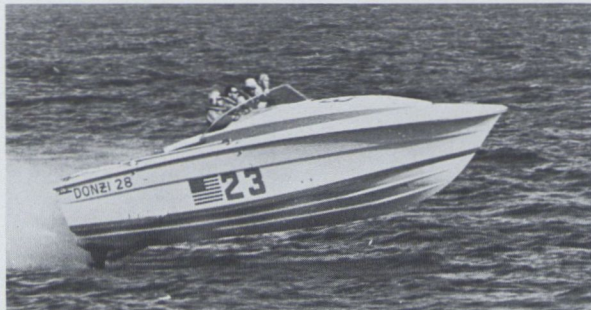

In the 1965 Sam Griffith Memorial Ocean Race, the 28' Donzi "Broadjumper" won overall and more than doubled the existing speed record.

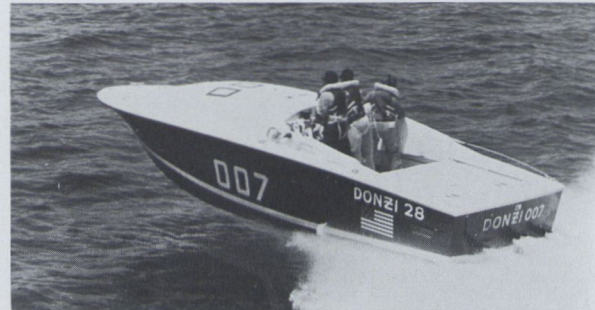

Miami-Nassau 1965: Don Aronow won overall and set new record of 55.6 mph average in his "Donzi 007".

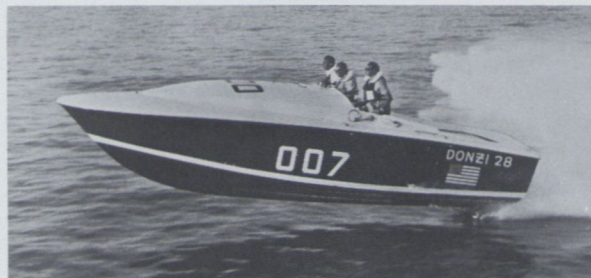

Around Nassau Sweepstakes, 1965: Aronow and 007 again — another win, another record. This one set the all-time ocean race speed record of 61.7 mph.

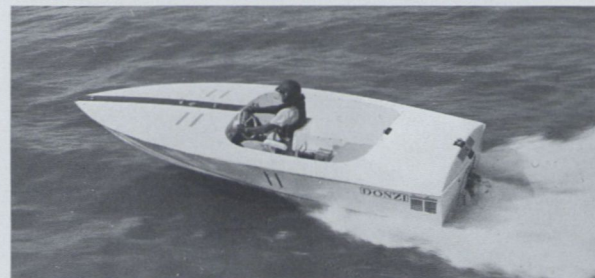

Fred and Judy Darwick entered their privately-owned Donzi 16 in three races including the rugged 9-hour marathon and won three first-in-class trophies.

DONZI 28-footers took 2nd and 4th over-all; 1st and 3rd went to 36-footers powered, respectively, by twin 550 h.p. engines in the 159 mile open ocean race — Miami to Key West — Nov. 6, 1964. No Donzi boat in the race suffered the slightest structural damage.

# DONZI MARINE

2940 N. E. 188th St.,  
NORTH MIAMI BEACH 62, FLORIDA  
Phone 305 / 945-7518